

IOWA STATE UNIVERSITY

ECpE Department

# EE455 Introduction to Energy Distribution Systems

Dr. Zhaoyu Wang

1113 Coover Hall, Ames, IA

[wzy@iastate.edu](mailto:wzy@iastate.edu)

# Nature of Loads

Acknowledgement: The slides are developed based in part on Distribution System Modeling and Analysis, 4<sup>th</sup> edition, William H. Kersting, CRC Press, 2017.

# Definitions

In order to describe the changing load, the following terms are defined:

## 1. Demand

- a. Load averaged over a specific period of time
- b. Load can be kW, kvar, kVA, or VA
- c. Must include the time interval
- d. Example: The 15 min kW demand is 100 kW

## 2. Maximum demand

- a. Greatest of all demands that occur during a specific time
- b. Must include demand interval, period, and units
- c. Example: The 15 min maximum kW demand for the week was 150 kW

## 3. Average demand

- a. The average of the demands over a specified period (day, week, month, etc.)
- b. Must include demand interval, period, and units
- c. Example: The 15 min average kW demand for the month was 350 kW

# Definitions

## 4. Diversified demand

- a. Sum of demands imposed by a group of loads over a particular period
- b. Must include demand interval, period, and units
- c. Example: The 15 min diversified kW demand in the period ending at 9:30 was 200 kW

## 5. Maximum diversified demand

- a. Maximum of the sum of the demands imposed by a group of loads over a particular period
- b. Must include demand interval, period, and units
- c. Example: The 15 min maximum diversified kW demand for the week was 500 kW

## 6. Maximum noncoincident demand

- a. For a group of loads, the sum of the individual maximum demands without any restriction that they occur at the same time
- b. Must include demand interval, period, and units
- c. Example: The maximum noncoincident 15 min kW demand for the week was 700 kW

## 7. Demand factor

- a. Ratio of maximum demand to connected load

# Definitions

## 8. Utilization factor

- a. Ratio of the maximum demand to rated capacity

## 9. Load factor

- a. Ratio of the average demand of any individual customer or a group of customers over a period to the maximum demand over the same period

## 10. Diversity factor

- a. Ratio of the “maximum noncoincident demand” to the “maximum diversified demand”

## 11. Load diversity

- a. Difference between “maximum noncoincident demand” and the “maximum diversified demand”

# Individual Customer Load

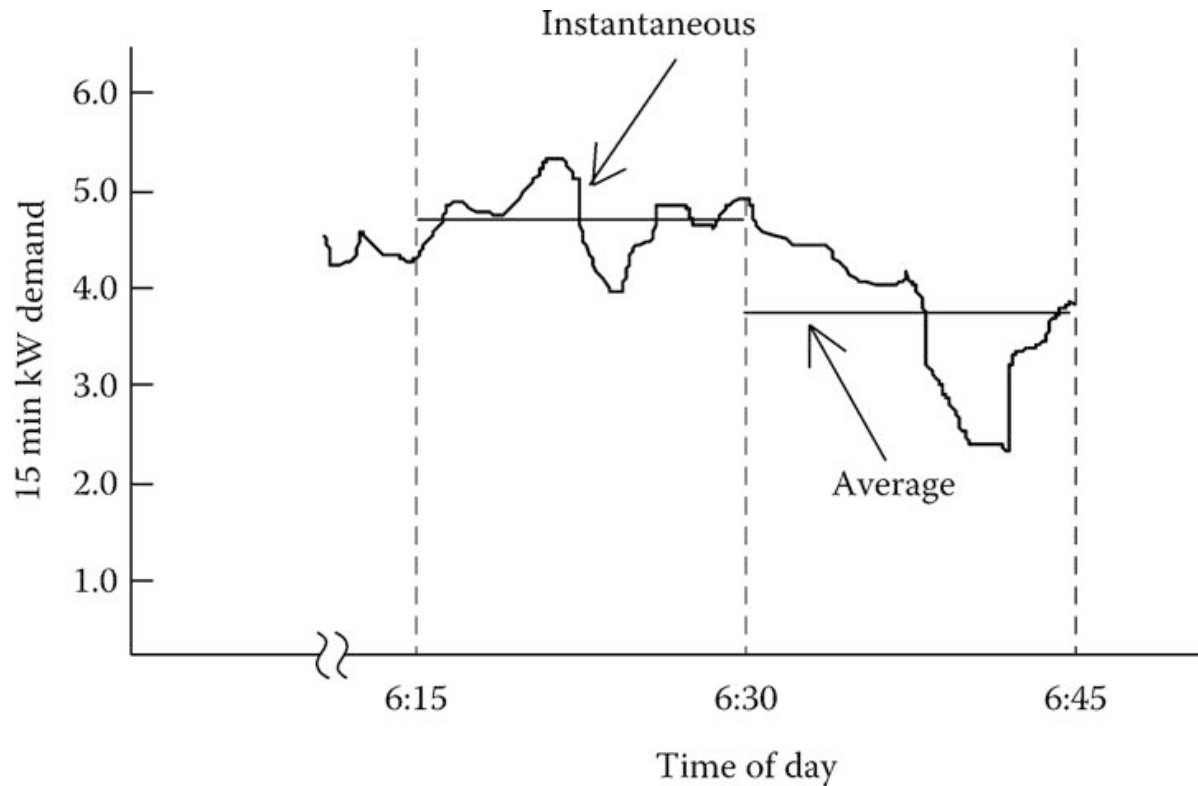

Fig.1 Customer demand curve

The demand curve is broken into equal time intervals. In Fig.1, the selected time interval is 15 min. In each interval, the average value of the demand is determined. The straight lines represent the average load in a time interval. The shorter the time interval, the more accurate will be the value of the load.

# Individual Customer Load

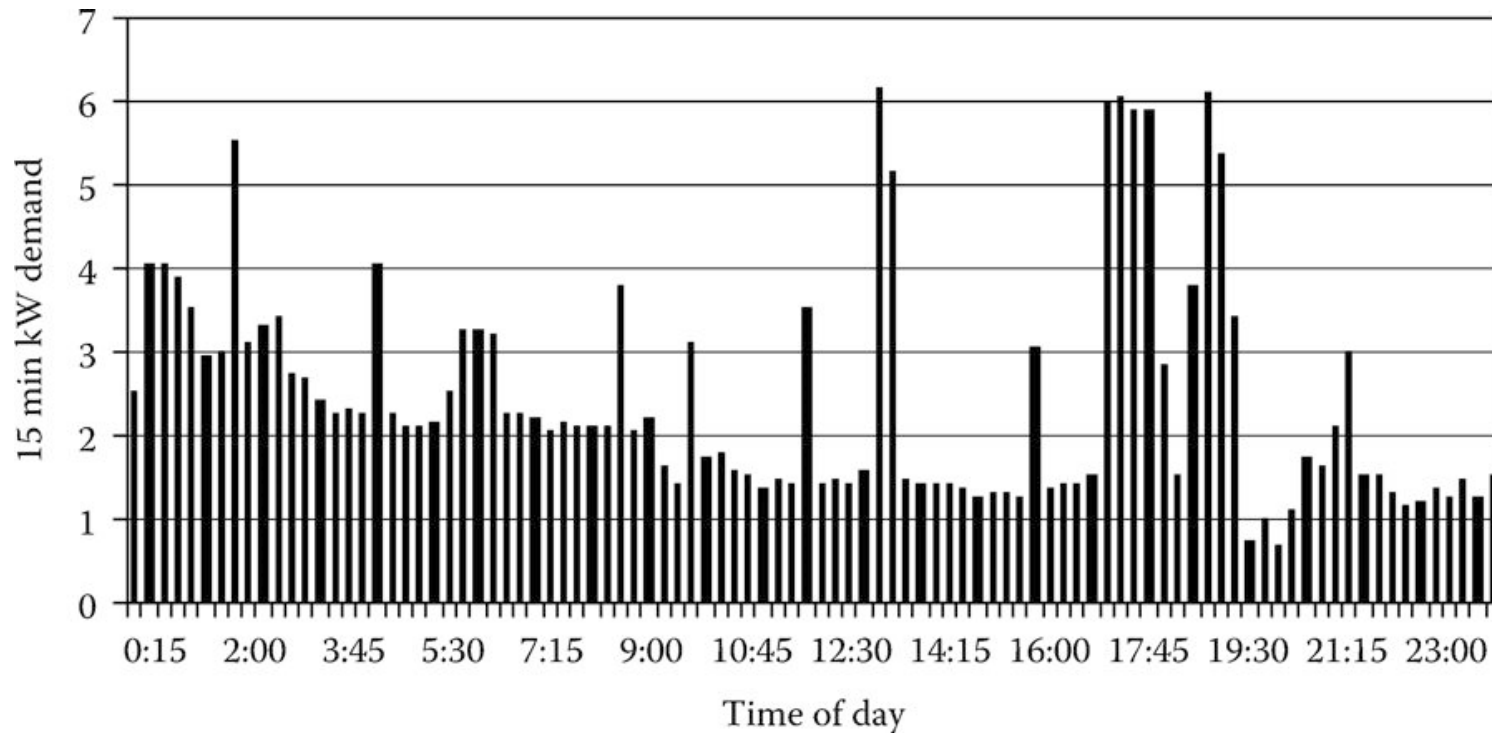

Fig.2 24-hour demand curve for customer#1 (from AMI, notice 15 min. incr.)

Calculate: 1) maximum demand; 2) Average demand; 3) Energy usage (total kWh); 4) Load factor

For this customer, the “15 min maximum kW demand” occurs at 13:15 and has a value of 6.18 kW.

# Individual Customer Load

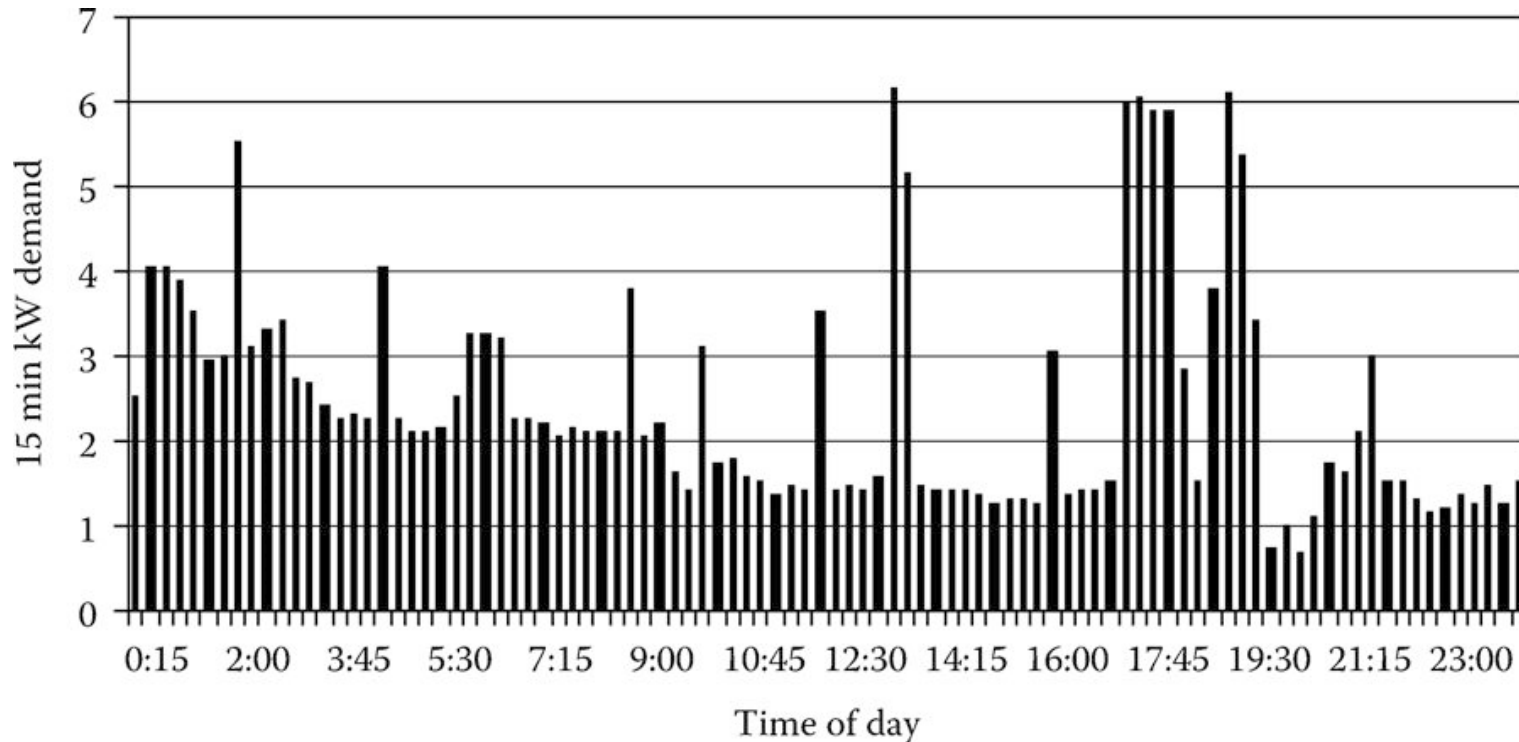

Fig.2 24-hour demand curve for customer#1 (from AMI, notice 15 min. incr.)

During the 24 h period, energy (kWh) will be consumed. The energy in kWh used during each 15 min time interval is computed by:

$$\text{kWh} = (\text{15min\_kW\_demand}) \times \frac{1}{4} \text{h}$$

Sum these over the time period.

8



# Individual Customer Load

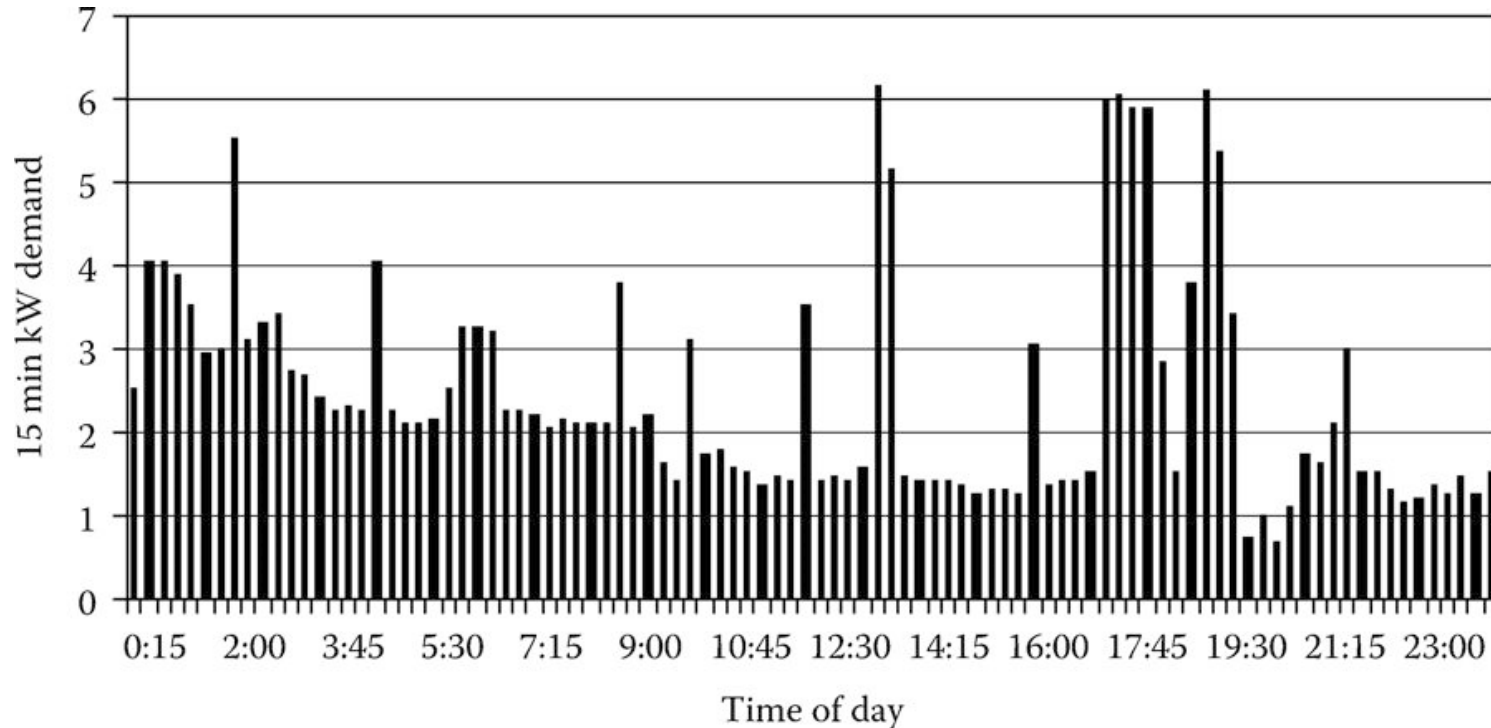

Fig.2 24-hour demand curve for customer#1 (from AMI, notice 15 min. incr.)

The total energy consumed during the day is the summation of all of the 15 min interval consumptions. The total energy consumed during the period by customer #1 is 58.96 kWh. The “15 min average kW demand” is computed

$$\text{Average\_demand} = \frac{\text{Total\_energy}}{\text{Hours}} = \frac{58.96}{24} = 2.46\text{kW}$$

# Individual Customer Load

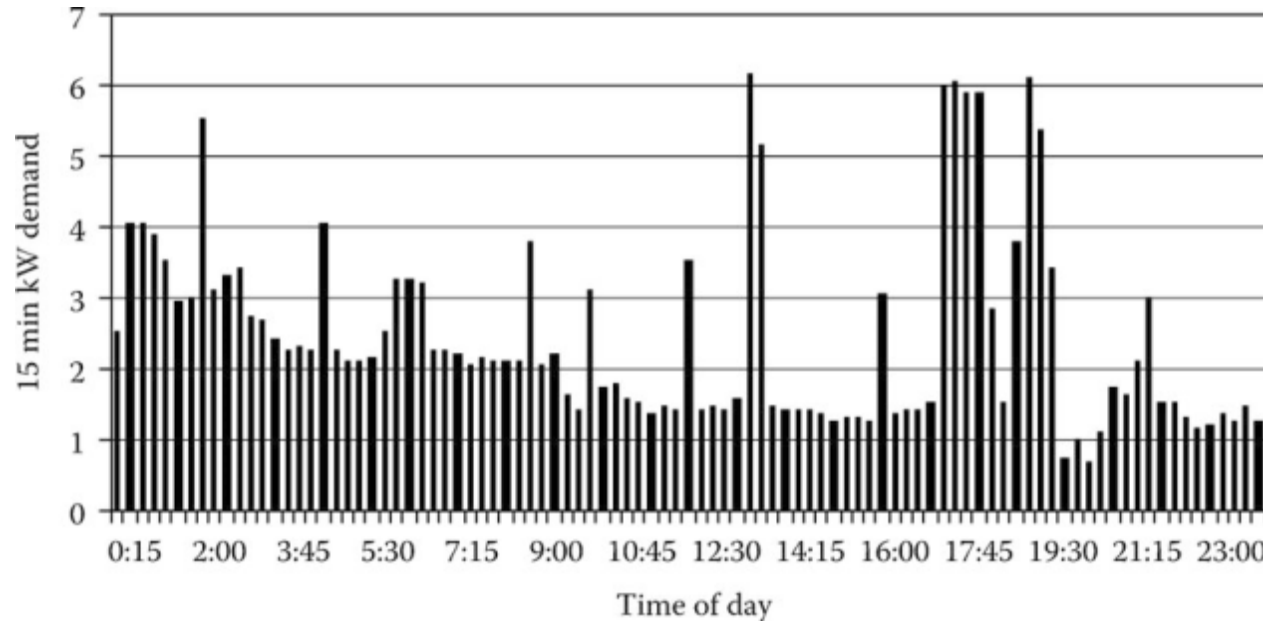

Fig.2 24-hour demand curve for customer#1 (from AMI, notice 15 min. incr.)

“Load factor” is a term that is often referred to when describing a load. It is defined as the ratio of the average demand to the maximum demand. In many ways, load factor gives an indication of how well the utility's facilities are being utilized. From the utility's standpoint, the optimal load factor would be 1.00 since the system has to be designed to handle the maximum demand. Sometimes utility companies will encourage industrial customers to improve their load factor. One method of encouragement is to penalize the customer on the electric bill for having a low load factor.

# Individual Customer Load

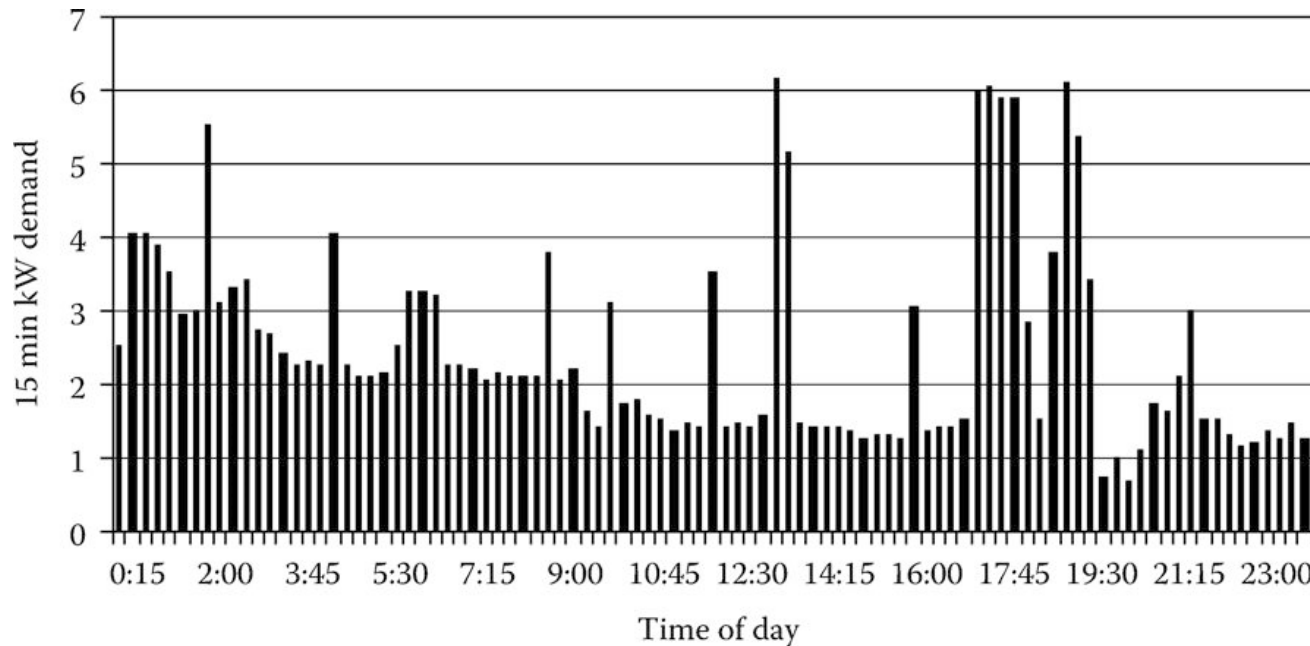

Fig.2 24-hour demand curve for customer#1 (from AMI, notice 15 min. incr.)

For customer #1 in Fig.2 the load factor is computed to be

$$\text{Load\_factor} = \frac{\text{Average\_15\_min\_kW\_demand}}{\text{Max\_15\_min\_kW\_demands}} = \frac{2.46}{6.18} = 0.40$$

System capacity must meet maximum demand.

Ideal load factor is 1.0.

# Distribution Transformer Loading

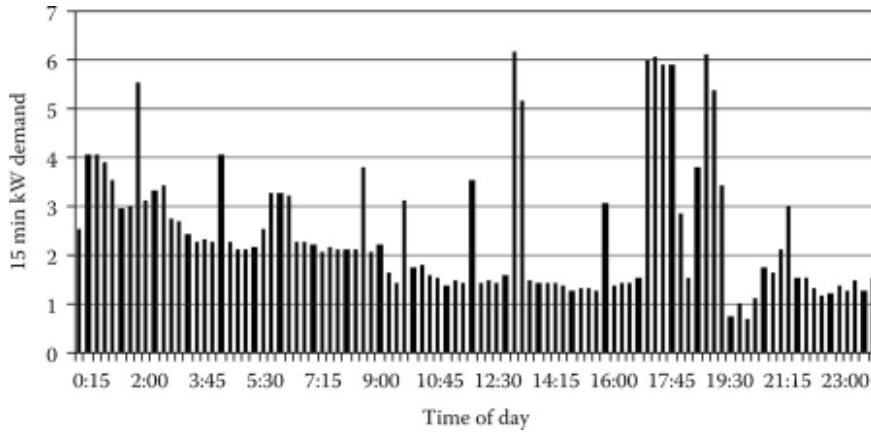

Fig.2 24-hour demand curve for customer#1

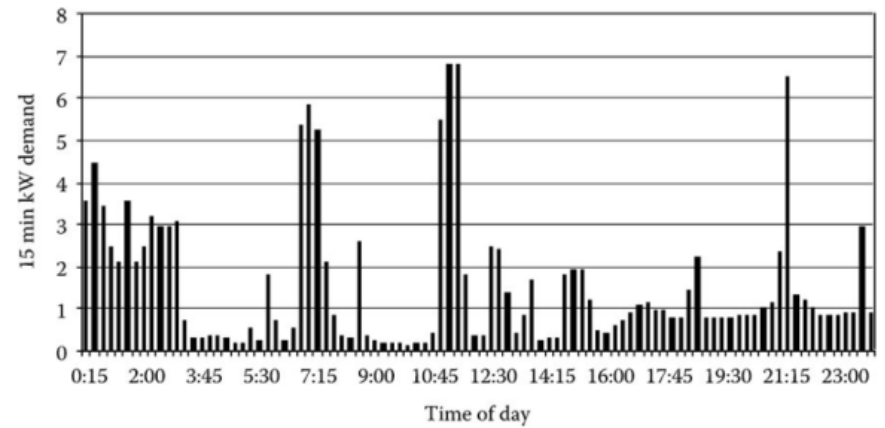

Fig.3 24-hour demand curve for customer#2

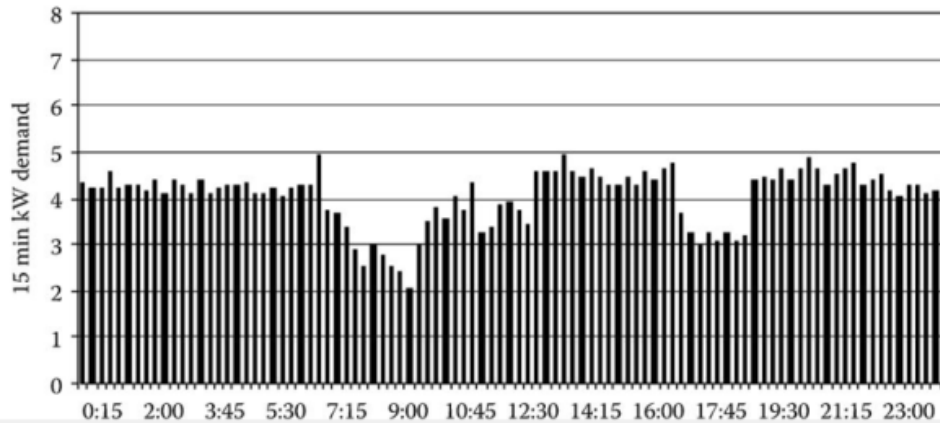

Fig.4 24-hour demand curve for customer#3

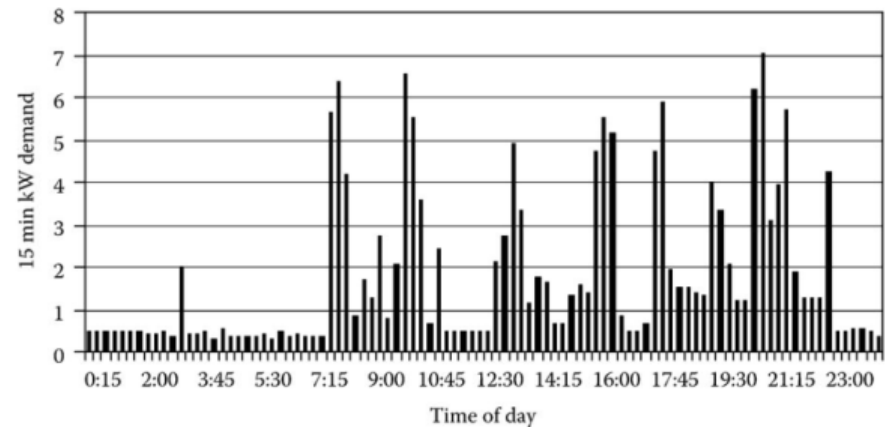

Fig.5 24-hour demand curve for customer#4

# Distribution Transformer Loading

Table 1 Individual Customer Load Characteristics

	Customer #1	Customer #2	Customer #3	Customer #4
Energy usage (kWh)	58.57	36.46	95.64	42.75
Maximum kW demand	6.18	6.82	4.93	7.05
Time of maximum kW demand	13:15	11:30	6:45	20:30
Average kW demand	2.44	1.52	3.98	1.78
Load factor	0.40	0.22	0.81	0.25

A distribution transformer will provide service to one or more customers. Each customer will have a demand curve similar to that of Fig. 2. However, the peaks and valleys and maximum demands will be different for each customer.

The load curves for the four customers show that each customer has its unique loading characteristic. The customers' individual maximum kW demand occurs at different times of the day. Customer #3 is the only customer who will have a high load factor. A summary of individual loads is given in Table 1. The four customers given in Table 1 demonstrate that there is great diversity between their loads. 13

# Diversified Demand

The sum of the four 15 kW demands for each time interval is the “diversified demand” for the group in that time interval, and in this case, the distribution transformer. The 15 min diversified kW demand of the transformer for the day is shown in Fig.6

**Maximum Diversified Demand:** It occurs at 17:30 and has a value of 16.16 kW.

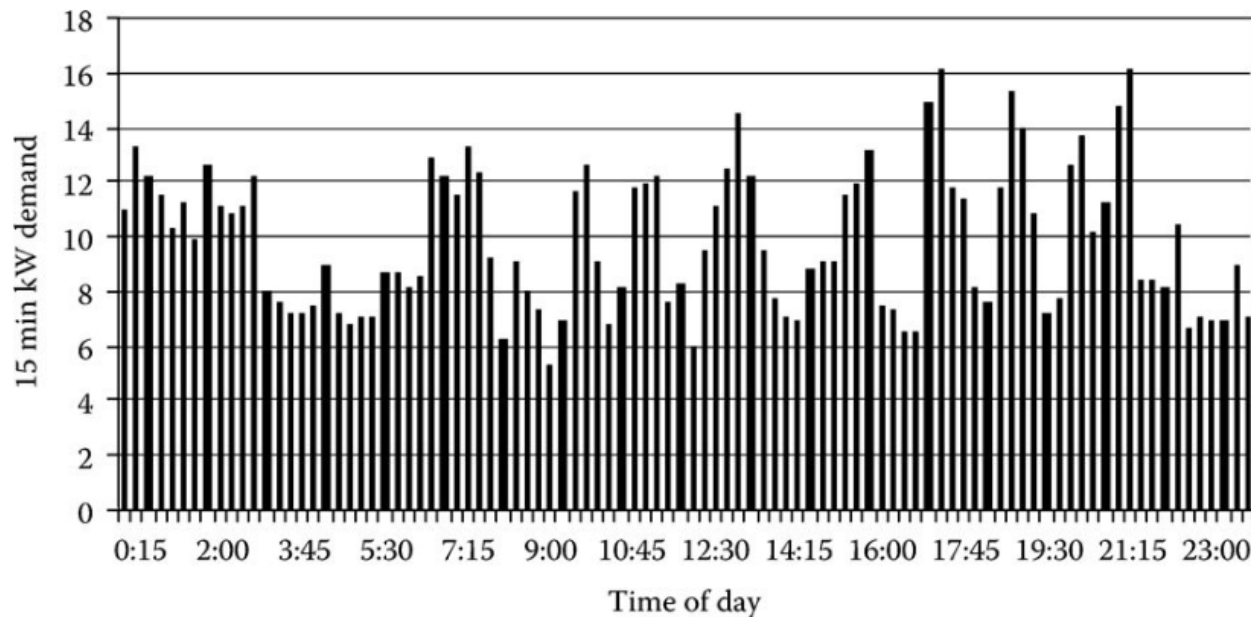

Fig.6 Transformer diversified demand curve

# Maximum Noncoincident Demand

The “15 min maximum noncoincident kW demand” for the day is the sum of the individual customer 15 min maximum kW demands. For the transformer in question, the sum of the individual maximums

$$\text{Max\_noncoincident\_demand} = 6.18 + 6.82 + 4.94 + 7.05 = 24.98\text{kW}$$

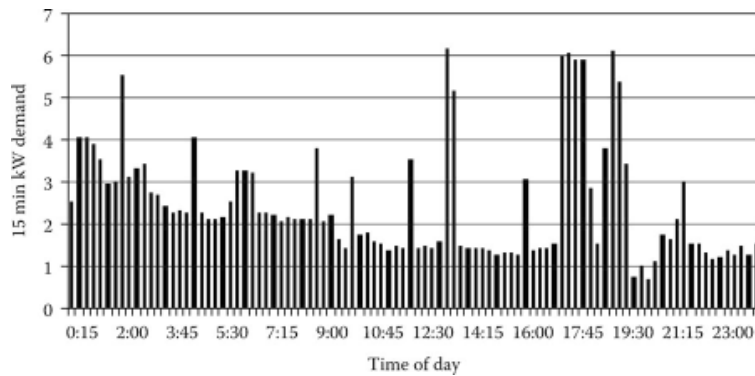

Fig.2 24-hour demand curve for customer#1

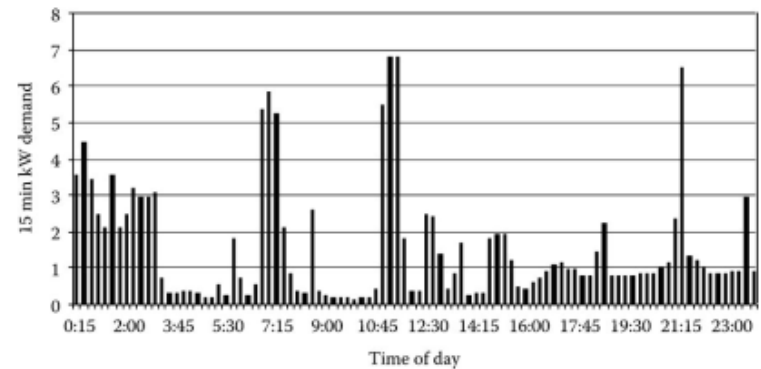

Fig.3 24-hour demand curve for customer#2

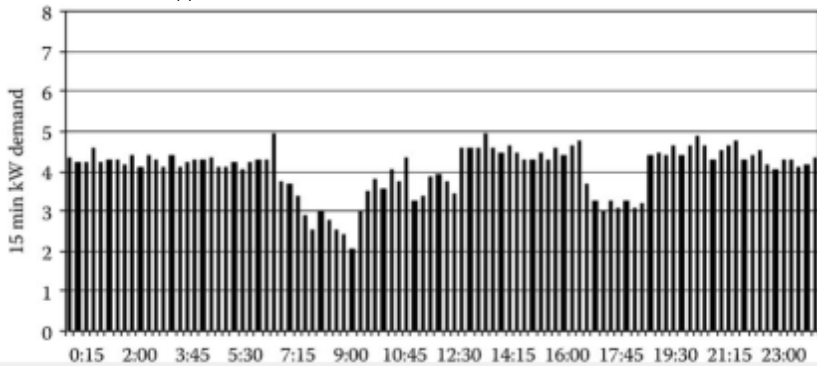

Fig.4 24-hour demand curve for customer#3

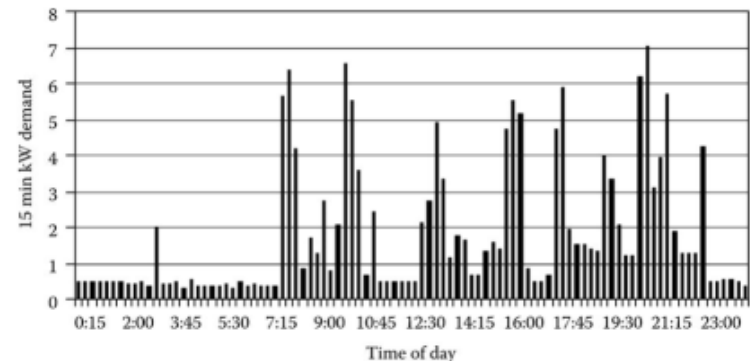

Fig.5 24-hour demand curve for customer#4

# Diversity Factor

By definition, diversity factor (DF) is the ratio of the maximum noncoincident demand of a group of customers to the maximum diversified demand of the group. With reference to the transformer serving four customers, the DF for the four customers would be:

$$\text{Max\_noncoincident\_demand} = 6.18 + 6.82 + 4.94 + 7.05 = 24.98\text{kW}$$

$$\text{Diversity\_factor} = \frac{\text{Max\_noncoincident\_demand}}{\text{Max\_diversified\_demand}} = \frac{24.98}{16.16} = 1.5458$$

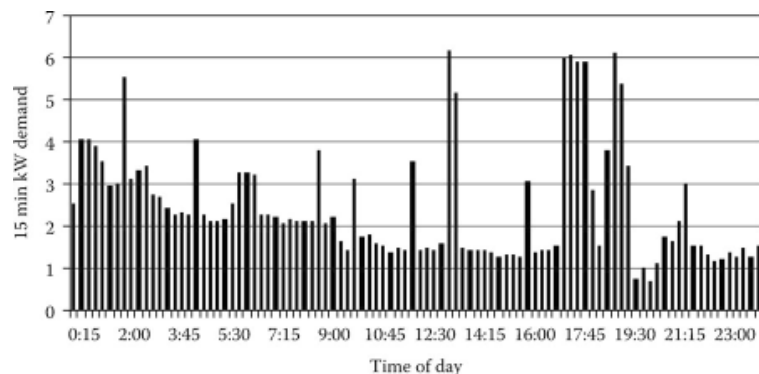

Fig.2 24-hour demand curve for customer#1

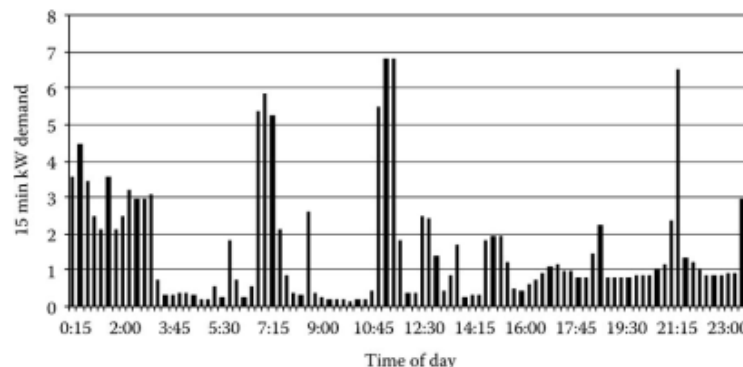

Fig.3 24-hour demand curve for customer#2

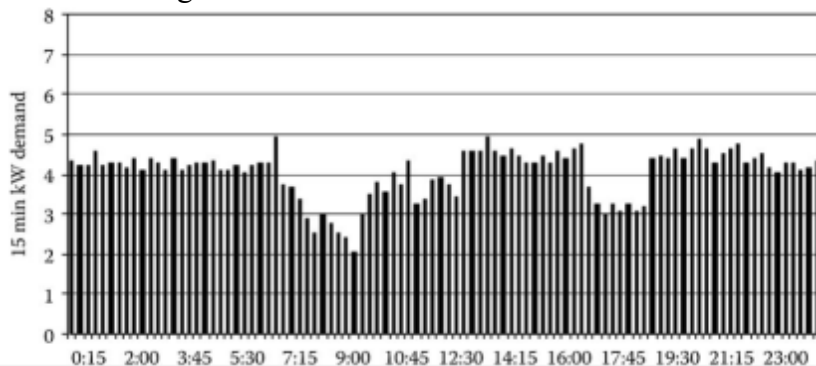

Fig.4 24-hour demand curve for customer#3

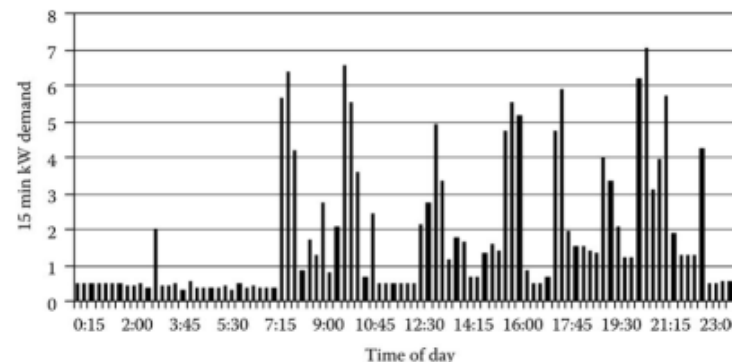

Fig.5 24-hour demand curve for customer#4



# Diversity Factor

Table 2 is an example of the DFs for the number of customers ranging from 1 up to 70. The table was developed from a different database than the four customers that have been discussed previously.

Table 2 Diversity Factors

N	DF	N	DF	N	DF	N	DF	N	DF	N	DF	N	DF
1	1.0	11	2.67	21	2.90	31	3.05	41	3.13	51	3.15	61	3.18
2	1.60	12	2.70	22	2.92	32	3.06	42	3.13	52	3.15	62	3.18
3	1.80	13	2.74	23	2.94	33	3.08	43	3.14	53	3.16	63	3.18
4	2.10	14	2.78	24	2.96	34	3.09	44	3.14	54	3.16	64	3.19
5	2.20	15	2.80	25	2.98	35	3.10	45	3.14	55	3.16	65	3.19
6	2.30	16	2.82	26	3.00	36	3.10	46	3.14	56	3.17	66	3.19
7	2.40	17	2.84	27	3.01	37	3.11	47	3.15	57	3.17	67	3.19
8	2.55	18	2.86	28	3.02	38	3.12	48	3.15	58	3.17	68	3.19
9	2.60	19	2.88	29	3.04	39	3.12	49	3.15	59	3.18	69	3.20
10	2.65	20	2.90	30	3.05	40	3.13	50	3.15	60	3.18	70	3.20

# Diversity Factor

A graph of the DFs is shown in Fig.8.

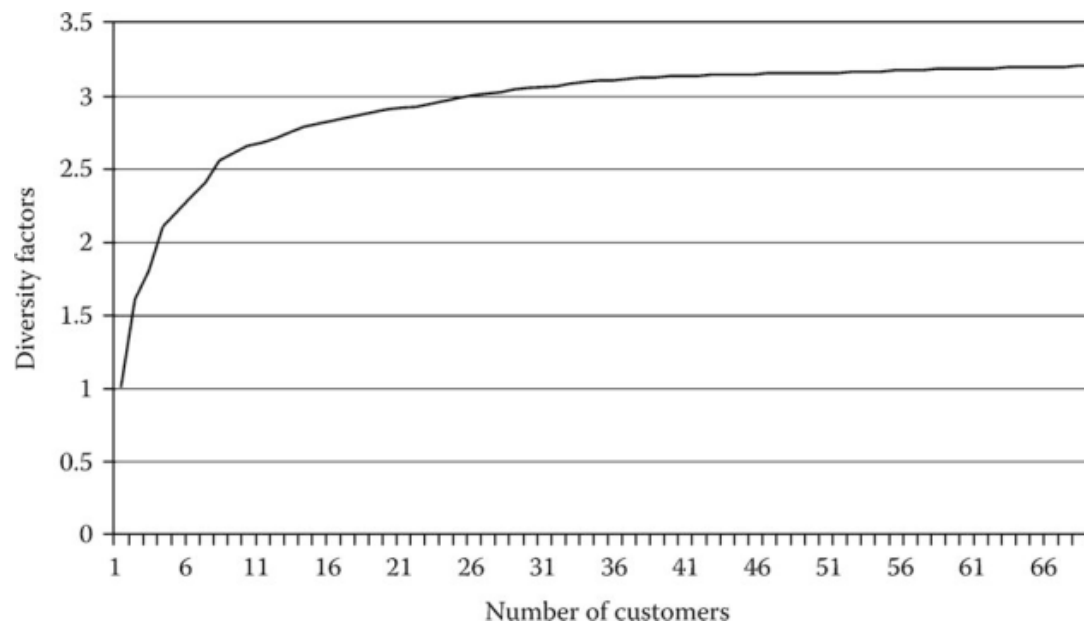

Fig.8 Diversity Factor

Note that, in Table 2 and Fig. 8, the value of the DF basically leveled out when the number of customers reached 70. This is an important observation because it means, at least for the system from which these DFs were determined, that the DF will remain constant at 3.20 from 70 customers and above. In other words as viewed from the substation, the maximum diversified demand of a feeder can be predicted by computing the total noncoincident maximum demand of all of the customers served by the feeder and dividing by 3.2.

# Demand Factor

## Customer #1

Peak demand is 6.18 kW.

Assume total connected load is 35kW.

$$\text{Demand\_factor} = \frac{\text{Max.\_demand}}{\text{Total\_connected\_load}}$$

This is for individual customers. We may be able to total up demand for all connected appliances and then apply demand factor to estimate peak demand of the customer.

# Utilization Factor

The utilization factor gives an indication of how well the capacity of an electrical device is being utilized. For example, the transformer serving the four loads is rated **15 kVA**. Using the 16.16 kW maximum diversified demand and assuming a power factor of 0.9, the 15 min maximum kVA demand on the transformer is computed by dividing the 16.16 kW maximum kW demand by the power factor and would be **17.96 kVA**. The utilization factor is computed to be:

$$\text{Utilization\_factor} = \frac{\text{Max\_kVA\_demand}}{\text{Transformer\_kVA\_rating}} = \frac{17.96}{15} = 1.197$$

# Load Diversity

Load diversity is defined as the difference between the noncoincident maximum demand and the maximum diversified demand

For our example transformer with 4 customers:

$$\text{Load\_Diversity} = 24.97 - 16.16 = 8.81kW$$

# Feeder Load

In the analysis of a distribution feeder, “load” data will have to be specified. The data provided will depend upon how detailed the feeder is to be modeled and the availability of customer load data. The most comprehensive model of a feeder will represent every distribution transformer. When this is the case, the load allocated to each transformer needs to be determined.

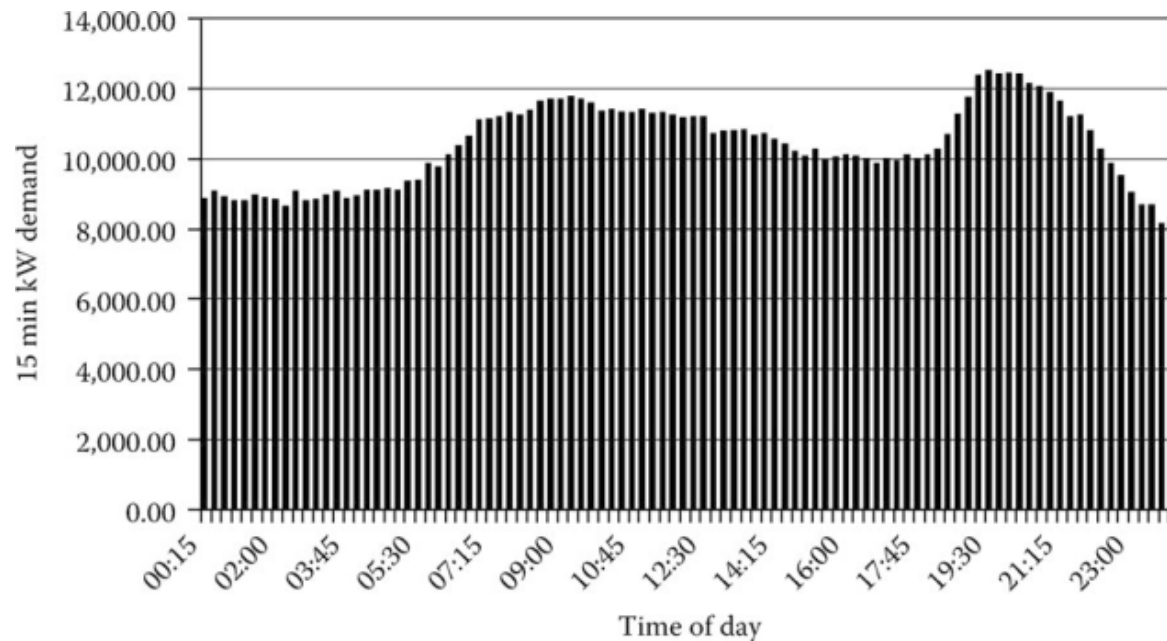

Fig.9 Feeder demand curve

# Application of Diversity Factors

The definition of the DF is the ratio of the maximum noncoincident demand to the maximum diversified demand. DFs are shown in Table 2. When such a table is available, then it is possible to determine the maximum diversified demand of a group of customers such as those served by a distribution transformer. That is, the maximum diversified demand can be computed by:

$$\text{Diversity\_factor} = \frac{\text{Max.\_noncoincident\_demand}}{\text{Max.\_diversified\_demand}}$$

$$\text{Max.\_diversified\_demand} = \frac{\text{Max.\_noncoincident\_demand}}{DF_n}$$

# But how could we know peak demand? (w/o demand mtr)

Many times the maximum demand of individual customers will be known either from metering or from knowledge of the energy (kWh) consumed by the customer. Some utility companies will perform a load survey of similar customers in order to determine the relationship between the energy consumption in kWh and the maximum kW demand. Such a load survey requires the installation of a demand meter at each customer's location.

Relate energy consumption to peak demand through study:

- Similar type of customers (residential)
- Metering on each customer for study

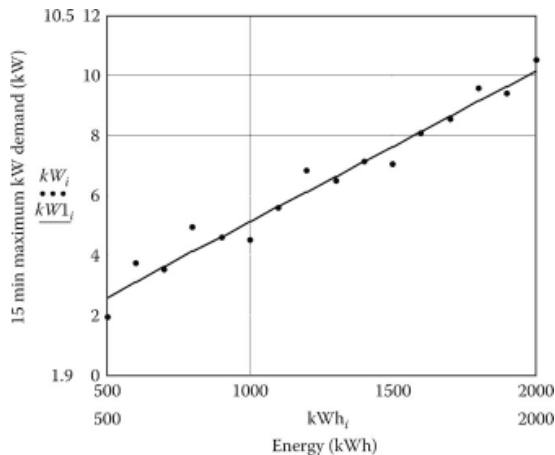

The plot of points for 15 customers along with the resulting equation derived

$$\text{Max. kW demand} = 0.1058 + 0.005014 * \text{kWh}$$

Fig.10 kW demand versus kWh for residential customers



# Example 1

Analyze a single phase **lateral**.

Lateral means “to the side” like a lateral pass.

Want to know voltages and flows.

We just know energy usage for each customer (kWh).

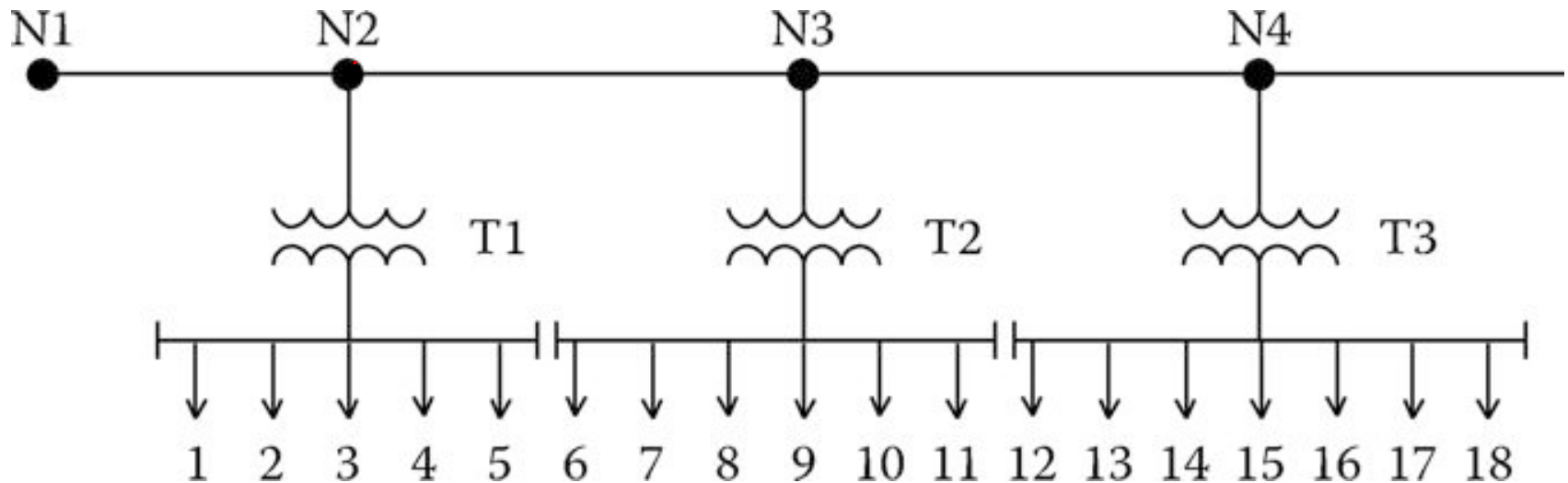

Fig.11 Single-phase lateral

# Example 1

A single-phase lateral provides service to three distribution transformers as shown in Fig.11.

The energy in kWh consumed by each customer during a month is known. A load survey has been conducted for customers in this class, and it has been found that the customer 15 min maximum kW demand is given by the equation

$$kW_{demand} = 0.2 + 0.008 * kWh$$

The kWh consumed by customer #1 is 1523 kWh. The 15 min maximum kW demand for customer #1 is then computed as

$$kW_1 = 0.2 + 0.008 * 1523 = 12.4$$

# Example 1

The results of this calculation for the remainder of the customers are summarized in the following table by transformer

## Transformer T1

Customer	#1	#2	#3	#4	#5
kWh	1523	1645	1984	1590	1456
kW	12.4	13.4	16.1	12.9	11.9

## Transformer T2

Customer	#6	#7	#8	#9	#10	#11
kWh	1235	1587	1698	1745	2015	1765
kW	10.1	12.9	13.8	14.2	16.3	14.3

## Transformer T3

Customer	#12	#13	#14	#15	#16	#17	#18
kWh	2098	1856	2058	2265	2135	1985	2103
kW	17.0	15.1	16.7	18.3	17.3	16.1	17.0

# Example 1

Q1: Determine for each transformer the 15 min noncoincident maximum kW demand, and using the DFs in Table 2, determine the 15 min maximum diversified kW demand.

Q2: Determine the 15 min noncoincident maximum kW demand and 15 min maximum diversified kW demand for each of the line segments

Tab.2 Diversity Factors

N	DF	N	DF	N	DF	N	DF	N	DF	N	DF	N	DF
1	1.0	11	2.67	21	2.90	31	3.05	41	3.13	51	3.15	61	3.18
2	1.60	12	2.70	22	2.92	32	3.06	42	3.13	52	3.15	62	3.18
3	1.80	13	2.74	23	2.94	33	3.08	43	3.14	53	3.16	63	3.18
4	2.10	14	2.78	24	2.96	34	3.09	44	3.14	54	3.16	64	3.19
5	2.20	15	2.80	25	2.98	35	3.10	45	3.14	55	3.16	65	3.19
6	2.30	16	2.82	26	3.00	36	3.10	46	3.14	56	3.17	66	3.19
7	2.40	17	2.84	27	3.01	37	3.11	47	3.15	57	3.17	67	3.19
8	2.55	18	2.86	28	3.02	38	3.12	48	3.15	58	3.17	68	3.19
9	2.60	19	2.88	29	3.04	39	3.12	49	3.15	59	3.18	69	3.20
10	2.65	20	2.90	30	3.05	40	3.13	50	3.15	60	3.18	70	3.20

# Example 1

Q1: Determine for each transformer the 15 min noncoincident maximum kW demand, and using the DFs in Tab.2, determine the 15 min maximum diversified kW demand.

$$T1: \text{Noncoin.}_{max.} = 12.4 + 13.4 + 16.1 + 12.9 + 11.9 = 66.7\text{kW}$$

$$\text{Max.}_{div.}_{demand} = \frac{\text{Noncoincident}_{max}}{\text{Diversity}_{factor}_{for_5}} = \frac{66.7}{2.20} = 30.3\text{kW}$$

$$T2: \text{Noncoin.}_{max.} = 12.9 + 13.8 + 14.2 + 16.3 + 14.3 + 17.0 = 81.6\text{kW}$$

$$\text{Max.}_{div.}_{demand} = \frac{\text{Noncoincident}_{max}}{\text{Diversity}_{factor}_{for_6}} = \frac{81.6}{2.30} = 35.5\text{kW}$$

$$T3: \text{Noncoin.}_{max.} = 17.0 + 15.1 + 16.7 + 18.3 + 17.3 + 16.1 + 17.0 = 117.5\text{kW}$$

$$\text{Max.}_{div.}_{demand} = \frac{\text{Noncoincident}_{max}}{\text{Diversity}_{factor}_{for_7}} = \frac{117.5}{2.40} = 49.0\text{kW}$$

# Example 1

**What size should the transformers be?**

Choose from 25, 37.5, or 50 kVA.

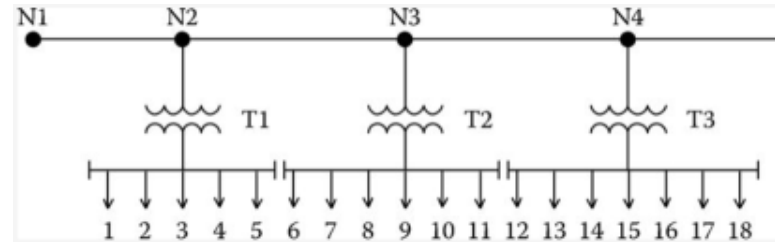

Based upon the 15 min maximum kW diversified demand on each transformer and an assumed power factor of **0.9**, the 15 min maximum kVA diversified demand on each transformer would be

$$\text{Max.}_k\text{VA.}_d\text{emand}(T1) = \frac{30.3}{0.9} = 33.7$$

$$\text{Max.}_k\text{VA.}_d\text{emand}(T2) = \frac{35.5}{0.9} = 39.4$$

$$\text{Max.}_k\text{VA.}_d\text{emand}(T3) = \frac{49.0}{0.9} = 54.4$$

The kVA ratings selected for the three transformers would be 25, 37.5, and 50 kVA, respectively. With those selections, only transformer T1 would experience a significant maximum kVA demand greater than its rating (135%).

# Example 1

Q2: Determine the 15 min noncoincident maximum kW demand and 15 min maximum diversified kW demand for each of the line segments

*Segment N1 to N2:*

The maximum noncoincident kW demand is the sum of the maximum demands of all 18 customers.

$$\text{Noncoin.}_{\text{max.}}_{\text{demand}} = 66.7 + 81.6 + 117.5 = 265.8\text{kW}$$

The maximum diversified kW demand is computed by using the DF for 18 customers

$$\text{Max.}_{\text{div.}}_{\text{demand}} = \frac{265.8}{2.86} = 92.9\text{kW}$$

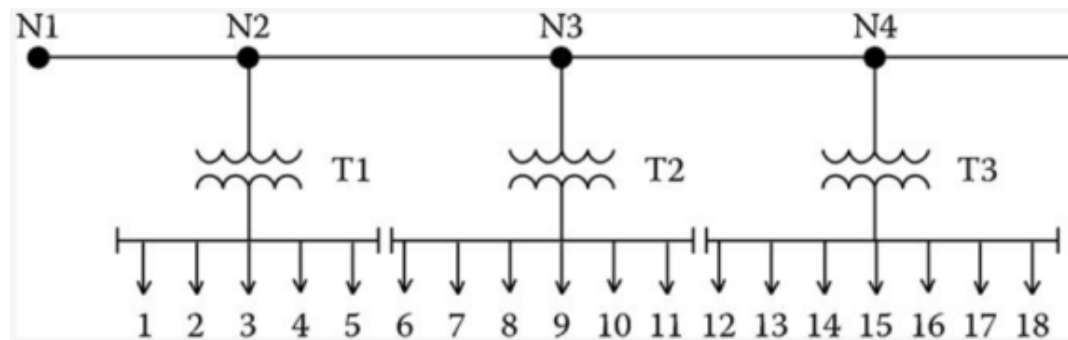

# Example 1

Q2: Determine the 15 min noncoincident maximum kW demand and 15 min maximum diversified kW demand for each of the line segments

*Segment N2 to N3:*

This line segment “sees” 13 customers. The noncoincident maximum demand is the sum of customer numbers 6 through 18. The DF for 13 (2.74) is used to compute the maximum diversified kW demand.

$$\text{Noncoin.}_\text{demand} = 81.6 + 117.5 = 199.1\text{kW}$$

$$\text{Max.}_\text{div.}_\text{demand} = \frac{199.1}{2.74} = 72.7\text{kW}$$

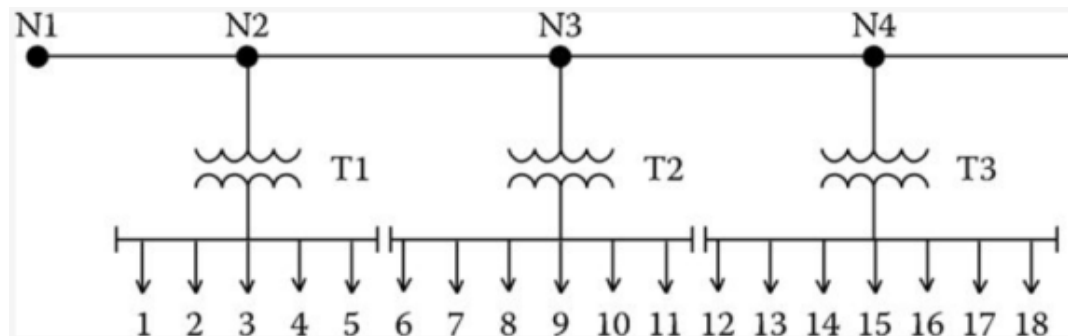



# Example 1

Q2: Determine the 15 min noncoincident maximum kW demand and 15 min maximum diversified kW demand for each of the line segments

*Segment N3 to N4:*

This line segment “sees” the same noncoincident demand and diversified demand as that of transformer T3.

$$\text{Noncoin.}_{\_}\text{demand} = 117.5\text{kW}$$

$$\text{Max.}_{\_}\text{div.}_{\_}\text{demand} = 49.0\text{kW}$$

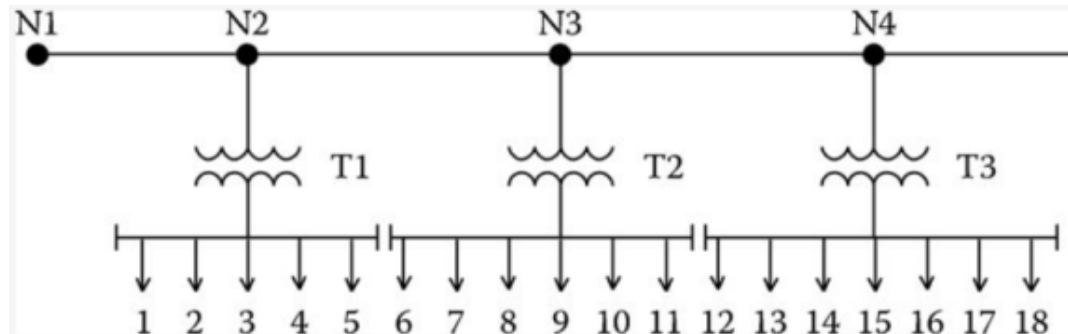

# Transformer load management:

If we know which customers are connected to which transformer, we can estimate the xfmr max. diversified demand to check for overloaded transformers.

- Prevent transformer failures
- Prevent transformer fires
- Better usage of capital (money)



# Another Approach - Allocation Factor (top down):

What if we know

- 1) The peak demand for the whole feeder
- 2) The apparent power rating of all the transformers connected to the feeder.

$$AF = \frac{\textit{Metered\_demand}}{\textit{kVA}_{total}}$$

where

- *Metered\_demand* can be either kW or kVA
- *kVA<sub>total</sub>* is the sum of the kVA ratings of all distribution transformers

The allocated load per transformer is then determined by

$$\textit{Transformer\_demand} = AF * \textit{kVA}_{\textit{transformer}}$$

# Example 2

Assume that the metered maximum diversified kW demand for the system of Example 2.1 is 92.9 kW. Allocate this load according to the kVA ratings of the three transformers.

$$\text{kVA}_{\text{total}} = 25 + 37.5 + 50 = 112.2$$

$$\text{AF} = \frac{92.9}{112.5} = 0.8258 \text{ kW/kVA}$$

The allocated kW for each transformer

$$\text{T1:kW} = 0.8258 * 25 = 20.64 \text{ kW}$$

$$\text{T2:kW} = 0.8258 * 37.5 = 30.97 \text{ kW}$$

$$\text{T3:kW} = 0.8258 * 50 = 41.29 \text{ kW}$$

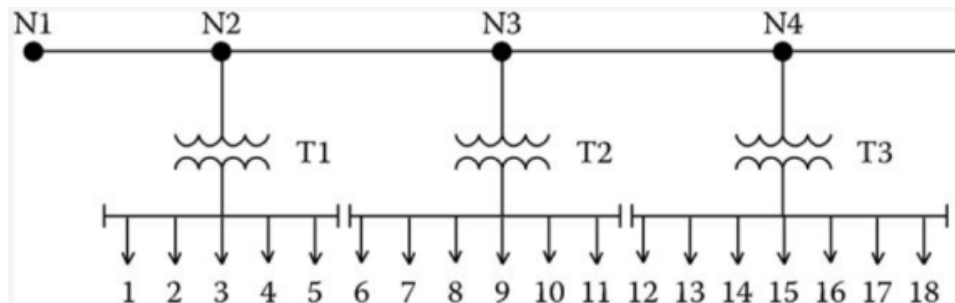

# Voltage Drop Calculations Using Allocated Loads

Will use two allocation methods:

- 1) **Diversity Factors** – bottom up approach
- 2) **Allocation factor** – when substation metering data available

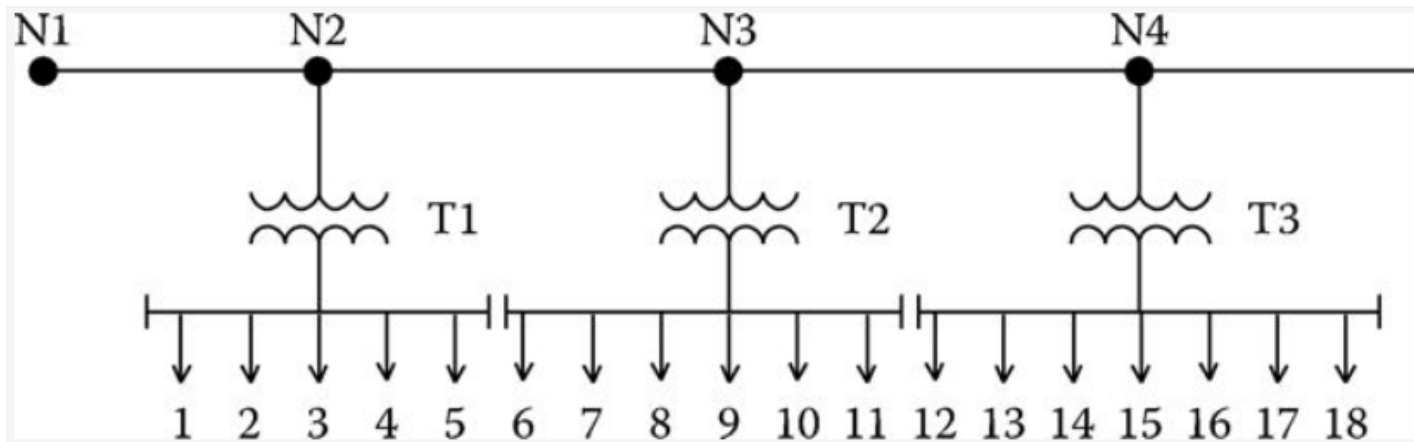

# Example 3

For the system of Example 2.1, assume the voltage at N1 is 2400 V and compute the secondary voltages on the three transformers using the DFs.

The system of Example 2.1 including segment distances is shown in following figure.

Assume that the power factor of the loads is 0.9 lagging.

The impedance of the lines are  $z = 0.3 + j0.6 \Omega/\text{mile}$

The rating of the transformers are as follows:

T1: 25 kVA, 2400 – 240 V,  $Z = 1.8/40\%$

T2: 37.5 kVA, 2400 – 240 V,  $Z = 1.9/45\%$

T3: 50 kVA, 2400 – 240 V,  $Z = 2.0/50\%$

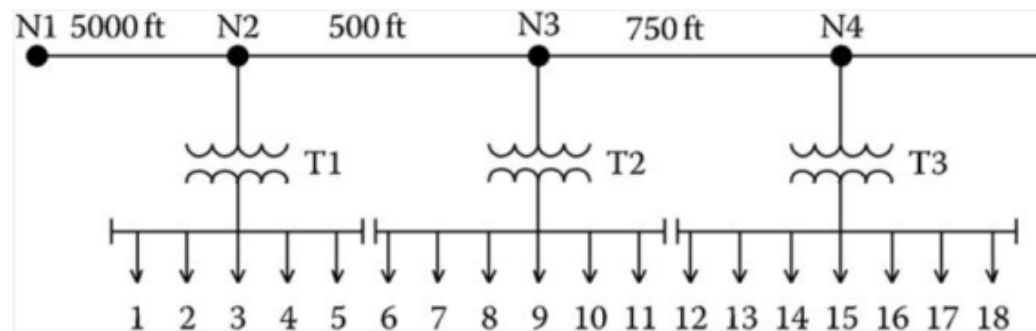

# Example 3

For the system of Example 2.1, assume the voltage at N1 is 2400 V and compute the secondary voltages on the three transformers using the DFs.

The system of Example 2.1 including segment distances is shown in following figure.

Assume that the power factor of the loads is 0.9 lagging.

The impedance of the lines are  $z = 0.3 + j0.6 \Omega/\text{mile}$

From Example 2.1 the maximum diversified kW demands were computed.

Using the 0.9 lagging power factor, the maximum diversified kW and kVA demands for the line segments and transformers

$$\text{Segment N1-N2: } P_{12} = 92.9 \text{ kW}, S_{12} = 92.9 + j45.0 \text{ kVA}$$

$$\text{Segment N2-N3: } P_{23} = 72.6 \text{ kW}, S_{23} = 72.6 + j35.2 \text{ kVA}$$

$$\text{Segment N3-N4: } P_{34} = 49.0 \text{ kW}, S_{34} = 49.0 + j23.7 \text{ kVA}$$

$$\text{Transformer T1: } P_{T1} = 30.3 \text{ kW}, S_{T1} = 30.3 + j14.7 \text{ kVA}$$

$$\text{Transformer T2: } P_{T2} = 35.5 \text{ kW}, S_{T1} = 35.5 + j17.2 \text{ kVA}$$

$$\text{Transformer T3: } P_{T3} = 49.0 \text{ kW}, S_{T1} = 49.0 + j23.7 \text{ kVA}$$

# Example 3

Convert transformer impedances to Ohms referred to the high voltage side

$$T1: Z_{base} = \frac{kV^2 * 1000}{kVA} = \frac{2.4^2 * 1000}{25} = 230.4 \Omega$$

$$Z_{T1} = (0.018 \angle 40) * 230.4 = 3.18 + j2.67 \Omega$$

$$T2: Z_{base} = \frac{kV^2 * 1000}{kVA} = \frac{2.4^2 * 1000}{37.5} = 153.6 \Omega$$

$$Z_{T2} = (0.019 \angle 45) * 153.6 = 2.06 + j2.06 \Omega$$

$$T3: Z_{base} = \frac{kV^2 * 1000}{kVA} = \frac{2.4^2 * 1000}{50} = 115.2 \Omega$$

$$Z_{T3} = (0.02 \angle 50) * 115.2 = 1.48 + j1.77 \Omega$$

Compute the line impedances:

$$N1 - N2: Z_{12} = (0.3 + j0.6) \frac{5000}{5280} = 0.2841 + j0.5682 \Omega$$

$$N2 - N3: Z_{23} = (0.3 + j0.6) \frac{500}{5280} = 0.0284 + j0.0568 \Omega$$

$$N3 - N4: Z_{34} = (0.3 + j0.6) \frac{750}{5280} = 0.0426 + j0.0852 \Omega$$



# Example 3

Calculate the current flowing in segment N1–N2:

$$I_{12} = \left( \frac{kW + jkvar}{kV} \right)^* = \left( \frac{92.9 + j45.0}{2.4 \angle 0} \right)^* = 43.0 \angle -25.84 \text{ A}$$

Calculate the voltage at N2:

$$V_2 = V_1 - Z_{12} I_{12}$$

$$V_2 = 2400 \angle 0 - (0.2841 + j0.5682) * 43.0 \angle -25.84 = 2378.4 \angle -0.4 \text{ V}$$

Calculate the current flowing into T1:

$$I_{T1} = \left( \frac{kW + jkvar}{kV} \right)^* = \left( \frac{30.3 + j14.7}{2.378 \angle -0.4} \right)^* = 14.16 \angle -26.24 \text{ A}$$

Calculate the secondary voltage referred to the high side:

$$V_{T1} = V_2 - Z_{T1} I_{T1}$$

$$V_{T1} = 2378.4 \angle -0.4 - (3.18 + j2.67) * 14.16 \angle -26.24 = 2321.5 \angle -0.8 \text{ V}$$

# Example 3

Compute the secondary voltage by dividing by the turns ratio of 10:

$$V_{\text{low}T2} = \frac{2331.1\angle -0.8}{10} = 233.1\angle -0.8 \text{ V}$$

Calculate the current flowing in line section N3–N4:

$$I_{34} = \left( \frac{\text{kW} + j\text{kvar}}{\text{kV}} \right)^* = \left( \frac{49.0 + j23.7}{2.3767\angle -0.4} \right)^* = 22.9\angle -26.27 \text{ A}$$

$$V_4 = V_3 - Z_{34}I_{34}$$

Calculate the voltage at N4:

$$V_4 = 2376.7\angle -0.4 - (0.0426 + j0.0852) * 22.9\angle -26.27 = 2375.0\angle -0.5 \text{ V}$$

$$I_{T3} = 22.91\angle -26.30 \text{ A}$$

The current flowing into T3 is the same as the current from N3 to N4:

Calculate the secondary voltage referred to the high side :

$$V_{T3} = V_4 - Z_{T3}I_{T3}$$

$$V_{T3} = 2375.0\angle -0.5 - (1.48 + j1.77) * 22.9\angle -26.27 = 2326.9\angle -1.0 \text{ V}$$

42

## Example 3

Compute the secondary voltage by dividing by the turns ratio of 10:

$$V_{low_{T3}} = \frac{2326.9 \angle -1.0}{10} = 232.7 \angle -1.0 \text{ V}$$

Calculate the percent voltage drop to the secondary of transformer T3. Use the secondary voltage referred to the high side :

$$V_{drop} = \frac{|V_1| - |V_{T3}|}{|V_1|} * 100 = \frac{2400 - 2326.11}{2400} * 100 = 3.0789\%$$

# Example 4

For the system of Example 2.1, assume the voltage at N1 is 2400 V, and compute the secondary voltages on the three transformers, allocating the loads based upon the transformer ratings. Assume that the metered kW demand at N1 is 92.9 kW.

The impedances of the line segments and transformers are the same as in Example 2.3.

Assume the load power factor is 0.9 lagging, and compute the kVA demand at N1 from the metered demand :

$$S_{12} = \frac{92.9}{0.9} \angle \cos^{-1}(0.9) = 92.9 + j45.0 = 103.2 \angle 25.84 \text{ kVA}$$

Calculate the  $AF$ :

$$AF = \frac{103.2 \angle 25.84}{25 + 37.5 + 50} = 0.9175 \angle 25.84$$

# Example 4

Allocate the loads to each transformer:

$$S_{T1} = AF * kVA_{T1} = (0.9175 \angle 25.84) * 25 = 20.6 + j10.0 \text{ kVA}$$

$$S_{T2} = AF * kVA_{T2} = (0.9175 \angle 25.84) * 37.5 = 31.0 + j15.0 \text{ kVA}$$

$$S_{T3} = AF * kVA_{T3} = (0.9175 \angle 25.84) * 50 = 41.3 + j20.0 \text{ kVA}$$

Calculate the line flows:

$$S_{12} = S_{T1} + S_{T2} + S_{T3} = 92.9 + j45.0 \text{ kVA}$$

$$S_{23} = S_{T2} + S_{T3} = 72.3 + j35.0 \text{ kVA}$$

$$S_{34} = S_{T3} = 41.3 + j20.0 \text{ kVA}$$

# Example 4

Using these values of line flows and flows into transformers, the procedure for computing the transformer secondary voltages is exactly the same as in Example 2.3. When this procedure is followed, the node and secondary transformer voltages are

$$\begin{array}{ll} V_2 = 2378.1 \angle -0.4 \text{ V} & V_{\text{low}T_1} = 234.0 \angle -0.6 \text{ V} \\ V_3 = 2376.1 \angle -0.4 \text{ V} & V_{\text{low}T_2} = 233.7 \angle -0.8 \text{ V} \\ V_4 = 2374.9 \angle -0.5 \text{ V} & V_{\text{low}T_3} = 233.5 \angle -0.9 \text{ V} \end{array}$$

The percent voltage drop for this case is

$$V_{\text{drop}} = \frac{|V_1| - |V_{T3}|}{|V_1|} * 100 = \frac{2400 - 2334.8}{2400} * 100 = 2.7179\%$$

Thank You!

# Load Duration Curve

A “load duration curve” can be developed for the transformer serving the four customers. Sorting in a descending order, the kW demand of the transformer develops the load duration curve shown in Fig.7.

The load duration curve plots the 15 min kW demand versus the percent of time the transformer operates at or above the specific kW demand. For example, the load duration curve shows the transformer operates with a 15 min kW demand of 12 kW or greater 22% of the time. This curve can be used to determine whether or not a transformer needs to be replaced due to an overloading condition.

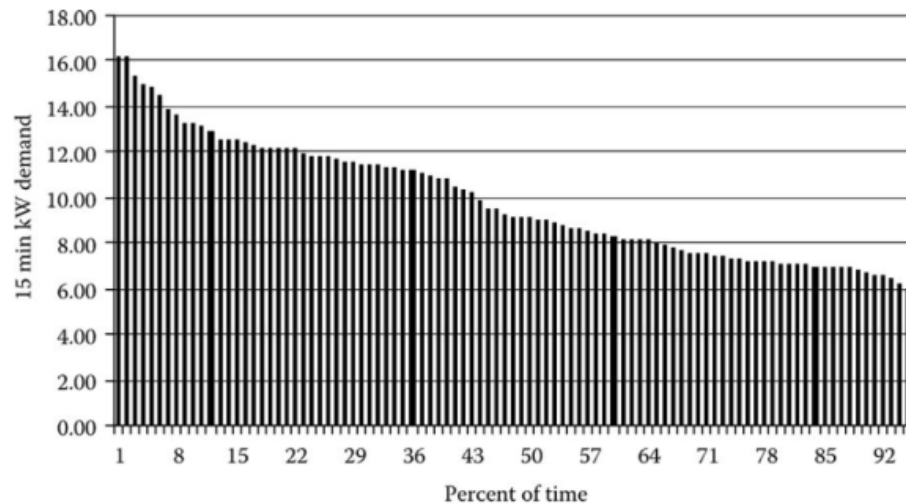

Fig.7 Transformer diversified demand curve